

TRIFECTA® X-SERIES

LASER ASSIST GAS SUPPLY SYSTEM

The Trifecta® X-Series is the preferred solution for reliable and continuous laser assist gases for delivery pressures up to 450 psi and flow rates up to 15,000 scfh. Drawing liquid from a standard bulk tank, the Trifecta system boosts the liquid pressure by alternately feeding two liquid cylinders equipped with innovative multi-function pressure building vaporizers. The Trifecta solution has no down-time and minimal losses when compared with other laser assist gas solutions. This convenient solution eliminates high-pressure pumps, compressors, cylinder cradles and surge tanks.



Models X5, X10, X15



Visual Indication for Operation Modes



Integrated Bulk Tank Pressure Sensor



Dual Relief Valve Assembly



Two Main Connections Simplify Installation

PRODUCT HIGHLIGHTS

- System utilizes standard low-pressure bulk tank to lower investment and use existing assets
- No downtime – system maintains pressure and flow when bulk tank is filled and eliminates excessive product losses associated with high-pressure bulk tanks
- Cylinders switch by pressure instead of level to further reduce product loss and protect against pressure decay
- Robust design features streamlined all stainless steel piping with only five control valves and one integrated electronic control system (PLC) for increased durability and reliability
- Computer-controlled design simplifies installation, start-up and continuous operation
- Frame assembly features a protective top cover in a compact footprint with an elevated base for improved ventilation
- Available for Nitrogen, Argon or Oxygen* service
*Maximum delivery pressure of 350 psi for Oxygen service



Innovation. Experience. Performance.®

TRIFECTA® X-SERIES

LASER ASSIST GAS SUPPLY SYSTEM

SIMPLIFIED STAINLESS STEEL PLUMBING WITH PROTECTIVE TOP COVER



System Requirements

- 15 amp, 110 VAC power, dedicated circuit
- Bulk storage tank with 50 psig minimum pressure
- External vaporizer, minimum 550 psig working pressure, sized for maximum flow rate
- Two piping connections to bulk storage tank (liquid withdrawal & low phase instrument line)
- High-flow pressure regulation
- 100 psi nitrogen gas required for actuated valves (X15 model only)

Dimensions

Length	53"	1347 mm
Width	55"	1400 mm
Height	96"	2440 mm
Weight X5	1700 lbs	770 kg
Weight X10	1750 lbs	795 kg
Weight X15	1800 lbs	815 kg

MODELS

TRIFECTA X5 Up to 5,000 scfh at 450 psig (131 Nm³H at 31 bar)

TRIFECTA X10 Up to 10,000 scfh at 450 psig (263 Nm³H at 31 bar)

NEW MODEL TRIFECTA X15

TRIFECTA X15 Up to 15,000 scfh at 450 psig
(394 Nm³H at 31 bar)

- Automated ball valves for *high flow* and improved reliability
- Diagnostics system
- Utilizes HP² Technology

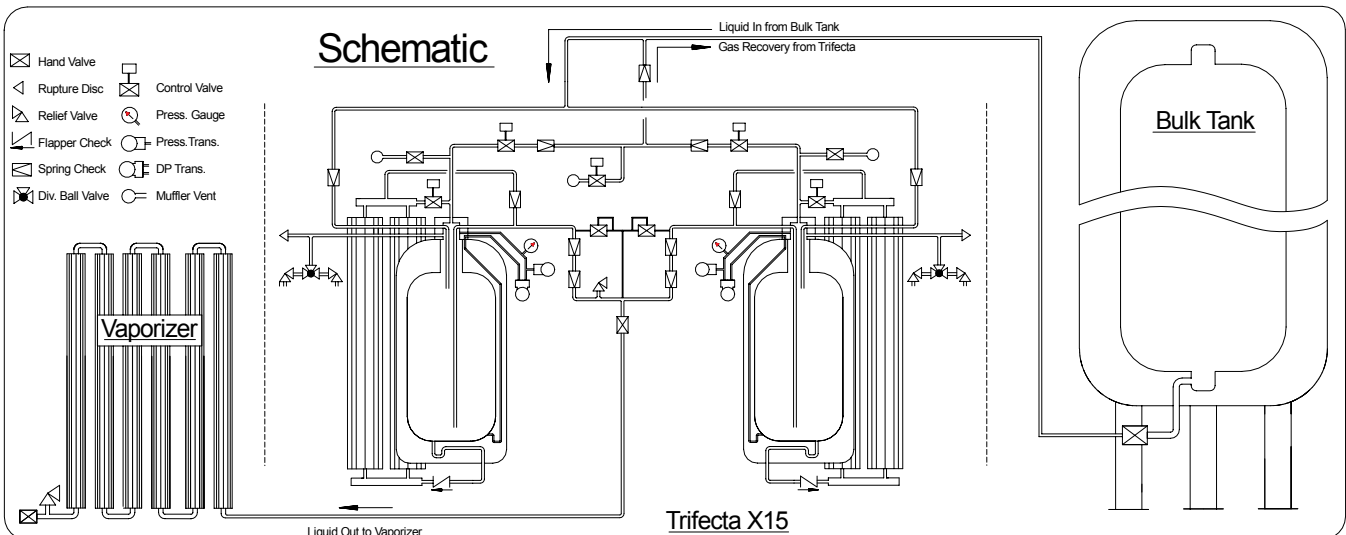
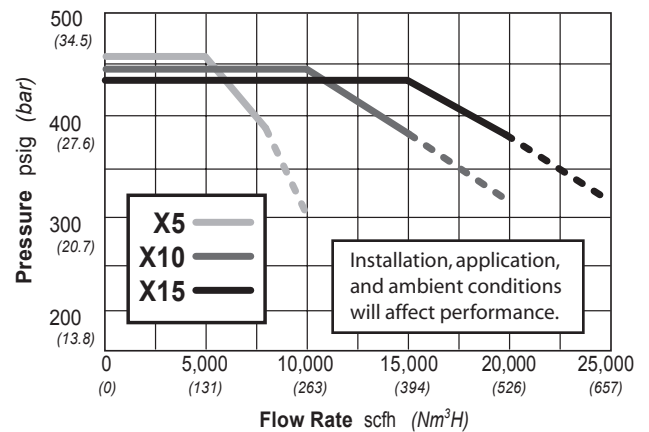

PATENT NUMBERS 5,924,291 - 5,937,655 - 5,121,609 - 5,231,838 - 6,542,848 - 6,782,339 - other patents pending.

Chart Inc.
U.S.: 1-800-400-4683
Worldwide: 1-952-758-4484



© 2009 Chart Inc.
P/N 11860073
www.chart-ind.com